

### NEW GENERATION OF PHOTOVOLTAIC MODULES

The photovoltaic modules **H580** have been designed for the rural electrification, data survey, telecommunication and special applications. Thanks to the versatility, main characteristic of the Helios modules, they are very appreciated and used either in the developing countries or in the European markets. The recent introduction of the high efficiency cells I-Max® in monocrystalline silicon, has highly increased their performance.

At the typical battery operating voltage (12-13 Volts) the I-Max® technology, developed by Helios for the high efficiency modules, allows to obtain, differently comparing with the traditional modules, a high increase of the current (10-17%). Such characteristic makes these modules particularly suitable for stand alone systems with batteries. Made by 36 high efficiency cells I-Max® 165 x 58mm in monocrystalline silicon, these modules have been designed in order to work under the toughest operative and environmental conditions. The Helios modules have been long lasting proven of a typical average lifetime of more than 30 years.

Furthermore every single cell and module produced have been several times tested and checked throughout the manufacturing process.

Interconnections between modules are easy, practical and optimized for all configuration voltages.

Robust construction and heavy duty anodized aluminium frame design makes this module suitable secure, simple and fast to be installed in many situations.



**H580 / 50W - 55W**

**Guaranteed power ≥ 80% 25 years**

Relative humidity up to 100%

Dimensions 750 x 524 x 34 ±1mm

Weight Kg. 4,60

Tolerance on technical data: ± 10%



### ELECTRICAL SPECIFICATIONS ( at 100mW/cm<sup>2</sup>, 25°C, AM 1,5 ) MODULE H580

Peak Power (Wp)	Watts	50	Watts	55
Short circuit current (Isc)	Amps	3,50	Amps	3,80
Open circuit voltage (Voc)	Volts	20,80	Volts	20,90
Voltage at maximum power (Vmp)	Volts	16,66	Volts	16,67
Current at maximum power (Imp)	Amps	3,00	Amps	3,30
<b>Typical Current at battery operating voltage (12,5V)</b>	<b>Amps</b>	<b>3,15</b>	<b>Amps</b>	<b>3,4</b>
NOCT (Nominal operating cell temperature)	°C	43±2	°C	43±2
Change of Voc with temperature (β)	mV/°C	-90	mV/°C	-90
Wind loading or surface pressure	N/m <sup>2</sup>	2400 (200 km/h equiv.)	N/m <sup>2</sup>	2400 (200 km/h equiv.)
Hailstone impact resistance	24mm	at 80 km/h	24mm	at 80 km/h
Storage and operating temperature	°C	da -40 a +95	°C	from -40 to +95
Maximum system voltage	Volts	600	Volts	600

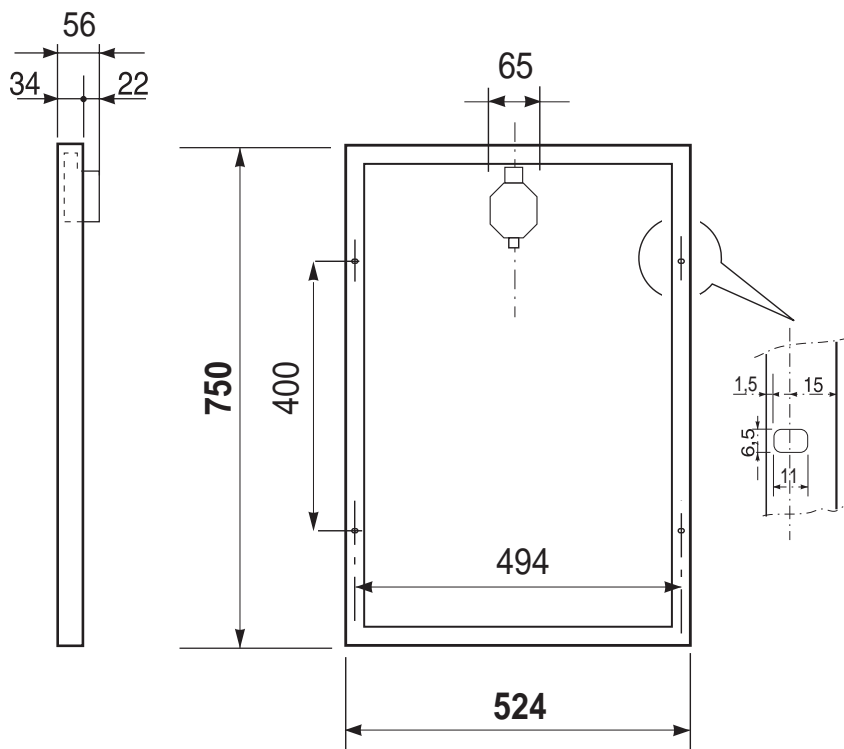

Tolerance  $\pm 1$ mm

## MODULE PHYSICAL FEATURES

Helios modules incorporate the latest manufacturing technologies, and extensive experience gained in the photovoltaic field as well as many professional installer suggestions.

The result is a module frame with 4 slotted holes practical and compact which helps and make faster the module installation.

The corner/frame assembly system, devised by Helios since 1982 has proven to be very efficient granting big sturdiness and perfect electric continuity between the frame components.

## MODULE CROSS SECTION

The cells are laminated in permanent way between sheets of ethylene vinyl acetate (EVA), tempered glass and white Tedlar, in order to offer an ideal protection against humidity penetration and salty corrosion. The tempered glass which main characteristic is the very high transparence towards the direct and diffused light, is fixed to the frame by means of silicone which assures a high protection against mechanic and environmental stress.

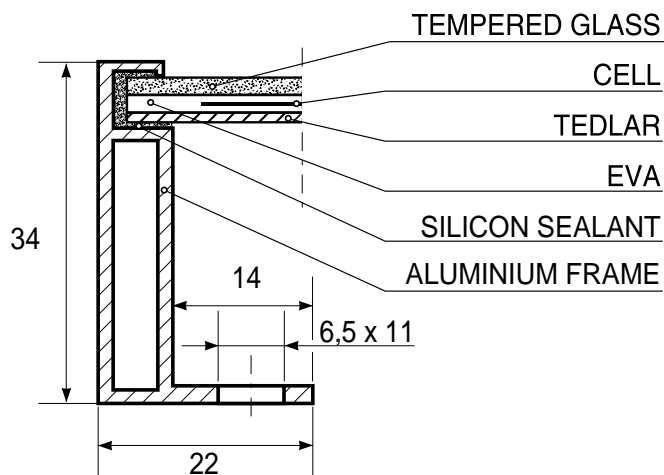

## JUNCTION BOX

A waterproof, high capacity junction box with protection grade IP65 the by-pass diode and suitable connection clamps. It is equipped with one cable gland PG9 for easy interconnections and it is made always keeping in mind the installer needing.

As a matter of fact:

1. All the screws can be easily tightened using flat or star screwdrivers.
2. The covers are fitted with not losable screws and are hooked to the junction box, for easy handling and maintenance.
3. All the connections are soldered for very long lasting and reliability.
4. Clamps and by-pass diode are printed circuit mounted for easy replacement in case of damage by lightning.



Helios Technology reserves the right to change the technical features without notice.