

SMALL-SIZE PHOTOVOLTAIC MODULES

The new photovoltaic modules **H245**, **H272**, **H372** have been designed by Helios Technology for rural electrification, data survey, telecommunications and special applications. Thanks to their high versatility, these modules are very appreciated and used for photovoltaic systems both in the developing countries and the European market. Their performance and reliability have been recently improved thanks to the introduction of high efficiency I-Max[®] monocrystalline cells.

At the typical battery operating voltage (12,5V) the I-Max[®] technology, developed by Helios Technology for its high-efficiency modules range, allows a remarkable increase of the current output (about 10-17%) compared to the traditional modules. This feature makes these modules very suitable for systems with batteries and attractive for low-budget and special applications.

These modules are composed of 38 and 72 high-efficiency I-Max[®] 165mm monocrystalline cells and they have been designed to operate under the toughest environmental conditions.

Up to now Helios Technology's modules have guaranteed an average lifetime more than 30 years.

Every cell and module are tested several times throughout the manufacturing process.

Easy and practical interconnections allow any voltage and configuration. A properly-designed anodized aluminium frame makes these modules safe, easy and quick to install in several situations.



MODULE H245	MODULE H272	MODULE H372
Guaranteed power $\geq 80\%$ 25 years	Guaranteed power $\geq 80\%$ 25 years	Guaranteed power $\geq 80\%$ 25 years
Relative humidity up to 100%	Relative humidity up to 100%	Relative humidity up to 100%
Dimensions 524 x 325 x 34 \pm 1mm	Dimensions 690 x 430 x 34 \pm 1mm	Dimensions 800 x 430 x 34 \pm 1mm
Weight kg 2,35	Weight kg 4,2	Weight kg 4,8
Tolerance on technical data: $\pm 10\%$	Tolerance on technical data: $\pm 10\%$	Tolerance on technical data: $\pm 10\%$

ELECTRICAL SPECIFICATIONS (at 100mW/cm², 25°C, AM 1,5)

	MODULE H245		MODULE H272		MODULE H372	
Maximum Power (Wp)	Watts	20	Watts	30	Watts	40
Short circuit current (Isc)	Amps	1,36	Amps	2,04	Amps	2,6
Open circuit voltage (Voc)	Volts	20,50	Volts	20,50	Volts	20,50
Voltage at maximum power (Vmp)	Volts	16,50	Volts	16,50	Volts	16,50
Current at maximum power (Imp)	Amps	1,21	Amps	1,82	Amps	2,43
Typical Current at battery operating voltage (12,5V)	Amps	1,27	Amps	1,88	Amps	2,50
NOCT (Nominal operating cell temperature)	°C	43 \pm 2	°C	43 \pm 2	°C	43 \pm 2
Change of Voc with temperature (β)	mV/°C	-90	mV/°C	-90	mV/°C	-90
Wind loading or surface pressure	N/m ² 2400 (200 km/heurequiv.)		N/m ² 2400 (200 km/heurequiv.)		N/m ² 2400 (200 km/heurequiv.)	
Hailstone impact resistance	28mm at 23 m/s		28mm at 23 m/s		28mm at 23 m/s	
Storage and operating temperature	°C	from -40 up to +95	°C	from -40 up to +95	°C	from -40 up to +95

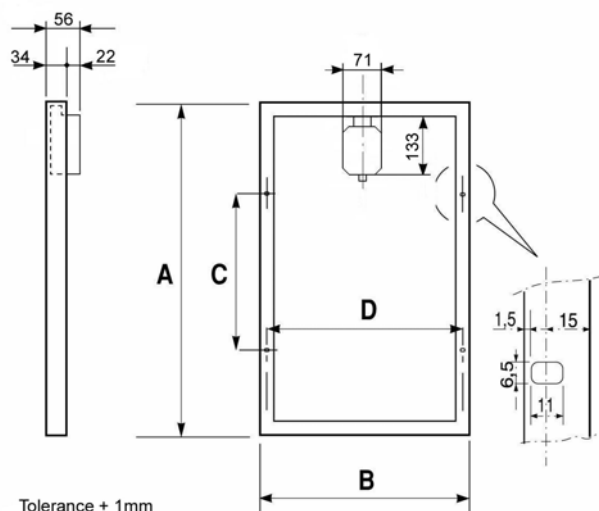

	A	B	C	D
H245	524 mm	325 mm	250 mm	295 mm
H272	690 mm	430 mm	400 mm	400 mm
H372	800 mm	430 mm	400 mm	400 mm

MODULE PHYSICAL FEATURES

Helios Technology modules are made using the most advanced technologies, thanks to the wide experience gained by Helios Technology in the PV field and the suggestions coming from skilled installers.

The result is a frame with 4 slotted holes, practical and compact, which allows a quick and easy installation of all Helios Technology's modules. The corner/frame assembly system, devised by Helios Technology in 1982, has proven its high efficiency guaranteeing mechanical strength and perfect electric continuity between the frame components.

MODULE CROSS SECTION

The cells are laminated in permanent way between sheets of ethylene vinyl acetate (EVA), tempered glass and white Tedlar, in order to offer an ideal protection against humidity penetration and salty corrosion. The tempered glass whose main characteristic is the high transparency to the direct and diffused light, is fixed to the frame by silicone sealant which assures an efficient protection against mechanical and environmental stress.

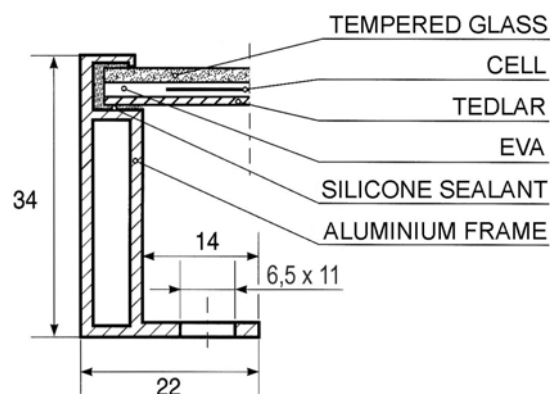

JUNCTION BOX

A waterproof, high capacity junction box with protection degree IP65 contains the by-pass diode and appropriate connection terminals. It is equipped with one PG9 cable glands for easy interconnections. The junction box is made always keeping in mind the requirements of the installers. As a matter of fact:

1. All the screws can be easily tightened using flat or star screwdrivers.
2. The covers are fitted with self-retaining screws and hooked to the junction box, for easy handling and maintenance.
3. All the connections are soldered for very long durability and reliability.
4. Connection terminals and by-pass diodes are mounted on a PC board for easy replacement in case of damage by lightning.

